



FITTING INSTRUCTIONS

Part Number: **5421240**
Product **Under Vehicle Protection (UVP) Front Kit**
Description:
Suited to **Toyota LandCruiser Prado 250**
vehicle/s:

WARNING

NOTE THE FOLLOWING:

- ◆ This product must be installed exactly as per these instructions using only the hardware supplied.
- ◆ Do not use this product for any vehicle make or model, other than those specified by ARB.
- ◆ Do not remove labels (if any) from this product.
- ◆ This product or its fixing must not be modified in any way.
- ◆ The installation of this product may require the use of specialized tools and/or techniques
- ◆ These instructions are correct as at the publication date. ARB Corporation Ltd. cannot be held responsible for the impact of any changes subsequently made by the vehicle manufacturer
- ◆ During installation, it is the duty of the installer to check correct operation/clearances of all components
- ◆ Work safely at all times
- ◆ Unless otherwise instructed, tighten fasteners to specified torque

ARB 4x4 ACCESSORIES

Corporate Head Office

42-44 Garden St
Kilsyth, Victoria
AUSTRALIA 3137

Tel: +61 (3) 9761 6622
Fax: +61 (3) 9761 6807

Australian enquiries
North & South American enquiries
Other international enquiries

sales@arb.com.au
sales@arbusa.com
exports@arb.com.au

www.arb.com.au

GENERAL CARE AND MAINTENANCE

By choosing ARB under vehicle protection, you have bought a product that is one of the most sought after 4WD products in the world. Your under vehicle protection panels are properly engineered, reliable, quality accessory that represents excellent value.



- While these panels have been engineered for strength and functionality, care and good judgment should be taken when traversing difficult off-road conditions to minimise damage to panels and vehicle.
- During servicing when panels are removed, ensure fasteners are re-fitted to the correct torque values.
- Inspect panels visually on a regular basis. Dirt and foreign matter should be washed out to minimise build-up around hot components. **BE VERY CAREFUL** when removing foreign matter with hands while vehicle is hot or running. Replace any components as necessary. This service can be performed by your local authorized ARB Stockist.

FITTING REQUIREMENTS

REQUIRED TOOLS FOR FITMENT OF PRODUCT:

10mm Socket	Torque Wrench
12mm Socket	Utility Knife / Multitool
14mm Socket	Small Flat Head Screwdriver
Socket Wrench	White Paint Marker

HAVE AVAILABLE THESE SAFETY ITEMS WHEN FITTING PRODUCT:













Protective eyewear		Hearing protection	
--------------------	---	--------------------	---

NOTE: 'WARNING' notes in the fitting procedure relate to OHS situations, where to avoid a potentially hazardous situation it is suggested that protective safety gear be worn or a safe work procedure be employed. If these notes and warnings are not heeded, injury may result.

FASTENER TORQUE SETTINGS:

SIZE	Torque Nm	Torque lbft
M6	9Nm	7lbft
M8	22Nm	16lbft
M10	44Nm	32lbft

PARTS LISTING

APPLICATION.	PART NO.	QTY	DESCRIPTION
Main Panels	4655729	1	 FRONT UVP PANEL
	4655730	1	 DIFFERENTIAL UVP PANEL
Front Trim/ Stone Panel Hardware	6151475	4	 U- NUT M6 x 1.0
	6151729	4	 FLANGE BOLT HXHD M6 x 1.0 x 20
Front panel Hardware	4581307	2	 WASHER FLAT M8 x 20 x 2
	4584344	6	 WASHER FLAT M10x22.9x2.1
	4722096	2	 CRUSH TUBE TOYOTA CROSSMEMBER
	6151478	2	 SERRATED FLANGE NUT M10 x 1.25
	6151730	4 / 8	 FLANGE BOLT HXHD M8 x 1.25 x 20
	6151745	2	 FLANGE SCREW HXHD M10 x 1.25 x 45
	6151769	4	 SCREW HXHD FL M10x1.25x30
Front Differential Panel Hardware	6151730	4 / 8	 FLANGE BOLT HXHD M8 x 1.25 x 20

FITTING PROCEDURE

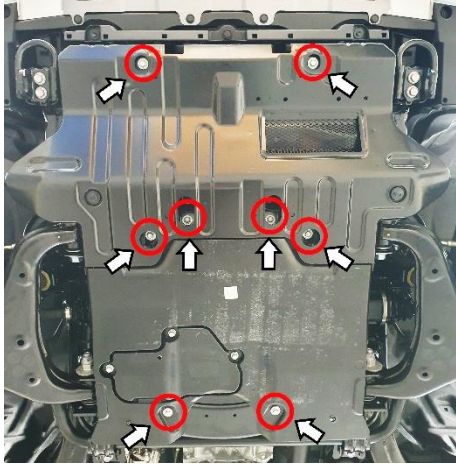

- Using a 12mm Socket, remove the eight M8 Bolts shown and the two OEM under vehicle protection panels.

The OEM panels and M8 bolts may be discarded.

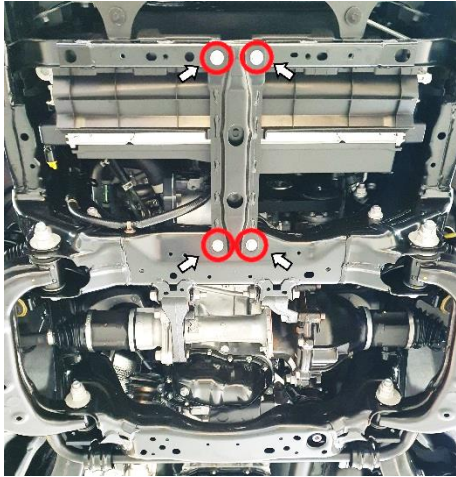

If vehicle is not fitted with a front crossmember support brace skip to Step 4.

- Remove the four M10 OEM bolts using a 14mm Socket.

The OEM bolts can be discarded.



- Using a small flathead screwdriver, remove the plastic scrivet on the back to release the front brace.

Brace and scrivet may be discarded.

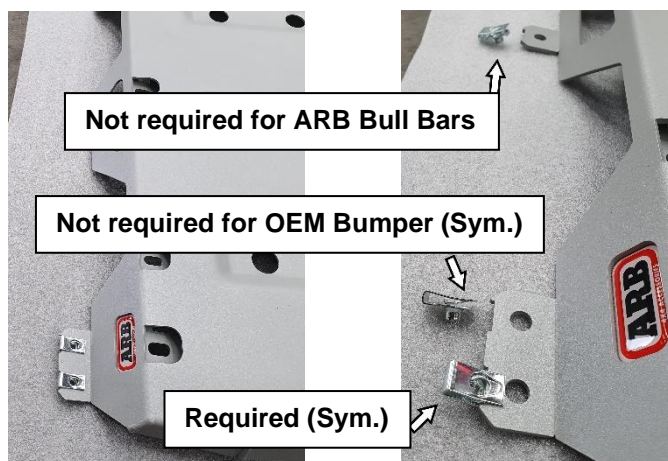

- Assemble the M6 U-Nuts to the Front UVP Panel by sliding into the gaps on the front edge as shown.

NOTE: Only THREE (the centre with outer most) U-Nuts are required when fitting a factory bumper fascia.

NOTE: The centre U-Nut is not to be fitted for fitment with ARB Bull bars.

HINT: Ensure that the U-Nuts are in the correct orientation and will align with the trim or stone panel before attaching to the UVP panel.

FITTING PROCEDURE

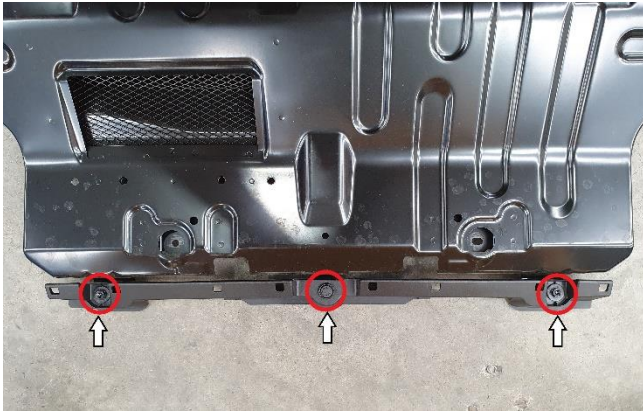

If vehicle is fitted with an ARB Bull bar skip to step 7.

5. Remove the plastic trim from the front OEM panel by removing the plastic scrivet and two M6 Fasteners using a 10mm socket.
Retain the Plastic Trim and M6 Bolts.
The scrivet may be discarded.

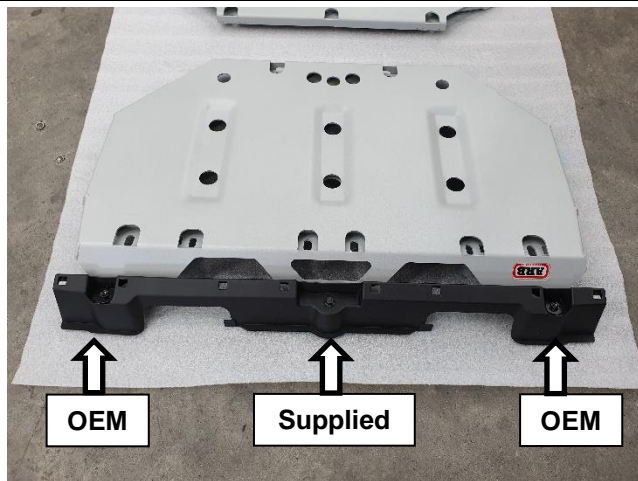

6. Attach the OEM Trim piece to the front edge of the Front UVP Panel with the two OEM M6 Flange Bolts and one supplied M6 Flange Bolt for the centre using the 10mm Socket.



7. Using a white paint marker, mark the hole centres on the lower plastic air dam through the outer most holes in the front cross member as shown.



8. Remove the plastic scrivets with a small flat head screwdriver to remove the lower plastic wind dam.
Retain the plastic air dam and plastic scrivets.

FITTING PROCEDURE



9. Using one of the supplied M8 Washers as a template, mark around the centre of the hole, repeat on other side.

This cutout can be oversized.

NOTE: The clearance is cut for the M10 Serrated Flange Nut, this may also be used as a template.

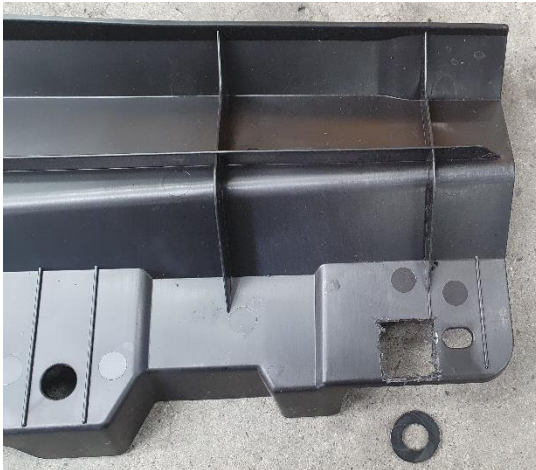

10. Using a utility knife or multitool, cut out the marked area as shown, repeat on the other side.

The hole must be large enough for the M10 nut to be able to sit flat when aligned with the hole in the front crossmember.

WARNING: Use Personal Protective Equipment as required.

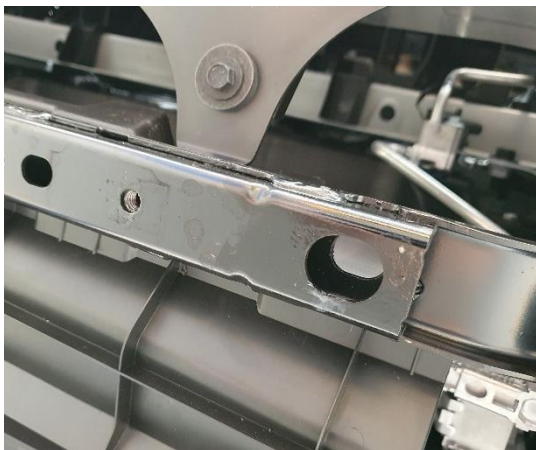

11. Re-attach the lower plastic air dam to the top of the crossmember with the OEM plastic scrivenets.

HINT: Ensure the M10 Serrated Flange Nut can sit in the cutout, flush with the top of the cross member and centred in the holes before putting the scrivenets back in.

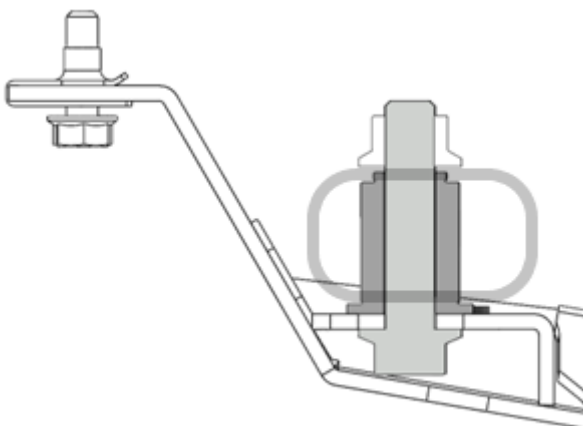

12. Take note of the cross section of the M10 x 45 flange bolt assembly.

The crush tube sits inside the cross member, with the bolt entering from the bottom of the UVP panel.

The Serrated Flange Nut sits on top of the cross member, in the cutout from the previous steps.

FITTING PROCEDURE

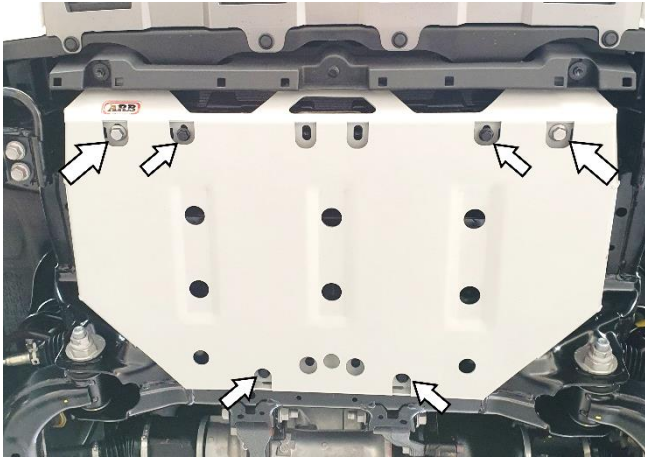

13. Fit the Front UVP panel with four M8 flange bolts and the two M10 x 45 flange bolts, crush tubes and serrated nuts from step 12.

The front M8 Bolts should have the 2mm M8 washer between the UVP and the chassis to ensure the panel is bolted flat against the cross member.

Only tighten to finger tight at this stage.

HINT: Consider using a lifting aid such as a transmission jack or seek assistance from a second person to help install the assembly. Alternatively, loosely fit the two M8s at the back of the panel to help take the weight.

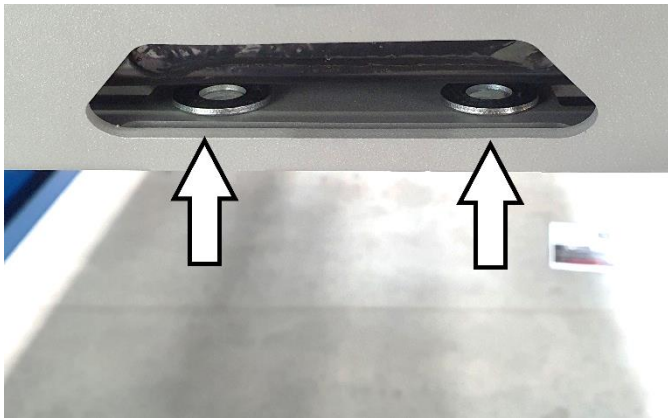

14. Slide two M10 washers on top at of the centre of the front UVP panel and align with the slots.

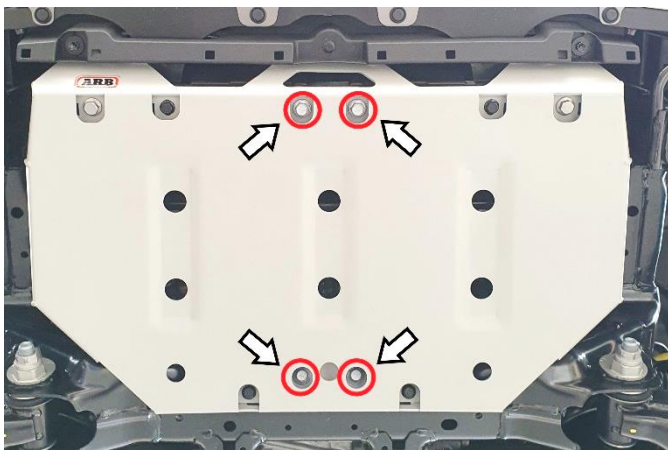

15. The M10 x 30 Bolts can be added with M10 washers on the flange as spacers.

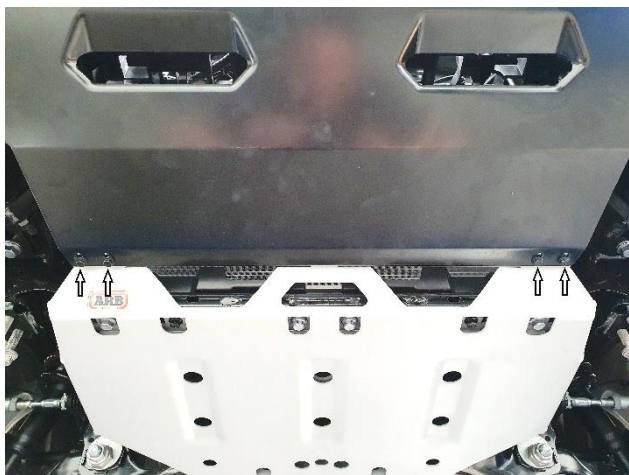

If not fitting an ARB Bull bar, skip to step 17.

16. Before tightening other bolts, fit the four M6 Bolts through the stone guard of the bull bar.

HINT: Loosen the bolts on the bull bar stone guard to assist in aligning the holes.

FITTING PROCEDURE

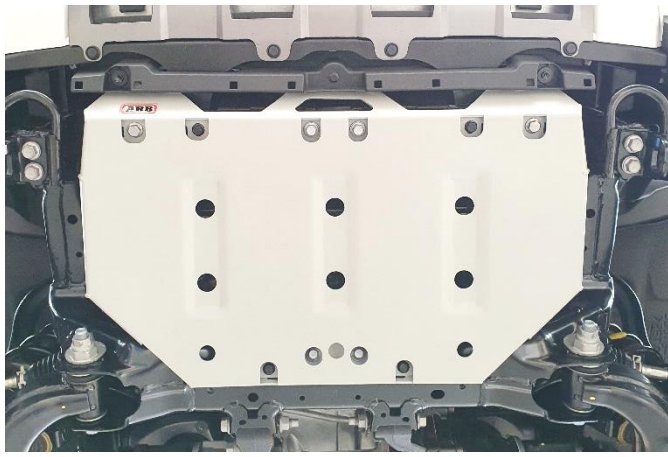

17. All bolts can now be tightened and torqued to specification.

 M6 - 9 Nm – 7lbft.

 M8 - 22 Nm – 16lbft.

 M10 - 44 Nm – 32lbft.

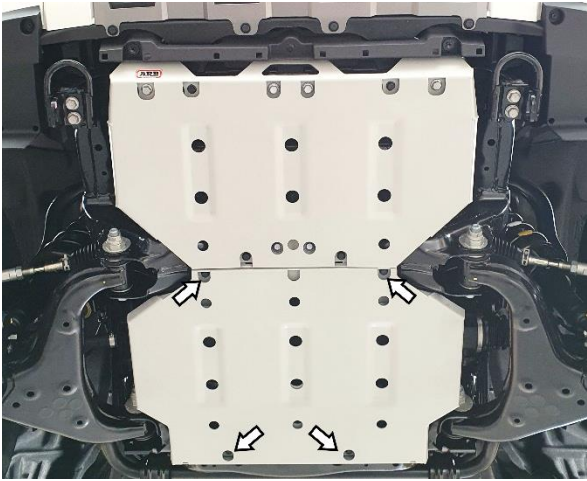

18. Install the Differential Panel using the four supplied M8 Flange bolts into the four threads in the chassis from the OEM panel locations.

Torque to specification.

 M8 - 22 Nm – 16lbft.

HINT: Loosely fit the bolts until all of the bolts are aligned before tightening.

FITTED PRODUCT



The Toyota LandCruiser Prado 250 Under Vehicle Protection Front Kit (5421240) is now installed.